

Dear Robert Kennedy Jr.

I am a man with vision and skills, nearly 72 years young. 1 aug 1954

As promised, I am sending you some project proposals I wrote some time ago.

Given how much time has passed, some of them may be outdated by today's standards.

Let's consider this our first exchange, with a view to potentially sharing knowledge in the future.

On a side note, I have to appear in court because someone took out an insurance policy on me under duress, which I do not agree with.

It would be great if JAG military personnel were present to arrest the judge and the perpetrators on the spot during this court hearing.

Warm regards, Rob Brekel aka Rinus Verhagen on Telegram

As far as the plans and their implementation go, we certainly have common ground.

We've had to wait a long time for a new monetary system to emerge so we can put our plans into action.

As for the Clarity Act, I think it's intended solely for the U.S. to sideline the banks there and circumvent the SWIFT system.

By constantly delaying it, the rest of the world will force the US to make progress through Operation Sandman by dumping their dollars.

This will also immediately bring the values of other currencies around the world closer together.

That is why we hope that the currency exchange will happen quickly, and that everyone will gain access to the QFS so that we do not need the banks to build the new world.

For years, I have been in discussions to purchase a remote estate in Europe that offers privacy.

I intend to use this with others as a conference center for project discussions.

It is essential that people with the drive and intelligence to share the technologies and their potential applications come together.

I helped a friend with his Tesla circuit solutions for generating electricity, and we got it working.

He can give demonstrations and explain how it works.

My Hydrobooster is part of my heating solution, because I've also built a thermal storage unit that stores heat; this heat comes from solar collectors and the Hydrobooster in the storage unit, which I can use to heat my home and pool and to operate a hot water circulation line.

For the home I plan to build, I have already made the window frames and windows in Tiffany glass, so I can construct it on the intended estate with the help of contractors.

I also want to have the garden landscaped into a botanical paradise, with a section for growing my own food.

One of the windows I've made is the GESARA–NESARA window, which would not look out of place in your national archives, where the Constitution is also stored.

The estate I can purchase is currently 6 hectares in size, but there are still adjacent plots for sale, so the area will expand, and more homes can be built on it by people participating in the projects.

It would be wonderful if projects that benefit all of humanity were adopted by communities across the globe.

To help bring this vision to life, I have previously gifted more than 300 people with free Zimbabwean dollars to inspire them.

Since then, more than 1,000 people have acquired the currency to replace the old system in their own regions with projects and take over regional governance.

My skills include:

Knowledge of installation technology, electronics, digital technology, programming in Basic, building and repairing PCs, product development, and organizational skills to execute everything.

To the government and NGOs, I am a criminal:

I spent 3.5 days in a police cell because I confronted a mayor about forcing Covid injections, and made it clear that this would be the end of him because he would be tried by tribunals for his actions.

Then there was a dispute with corrupt bailiffs who are robbing me for a contract I never entered into—they admit this themselves—yet I was still sentenced to a one-month suspended prison term if I were to make another statement to this bailiff.

Take my word for it, I will never let these corrupt scoundrels get away with it, and through a bar association, I have further cornered the bailiff and immediately put the judiciary in a tight spot.

Because on February 10, 2022, I had notified all the chief judges of the courts in the country of the genocide, and they were obligated to put an immediate stop to it, but failed to do so; therefore, in my view, they are complicit in the GENOCIDE.

Landgraaf 1 Aug 2021

Short version approach Humanitarian Projects.

Starting up the organization in the Netherlands, where an executive team will collect the project applications of incoming projects.

From the project applications already received, a selection will be made for Europe and outside Europe.

My plans are for the projects in Europe, but in cooperation with several like-minded people and project implementation by several groups in Europe.

To help people with project requests outside Europe to find the right entrance in their own country or continent.

Through consultation, taking stock together of the total number of projects and assessing the support for a collaboration within the plans of Europe, but also sharing this with people outside Europe.

Since it is currently unknown which solutions will become available from patents, proposed projects where solutions are based on patent releases will have to be assessed, and possibly adapted to the new circumstances.

It is important that own team members must be made free of worries, so that they can start up the organization unhindered.

There are project plans for the reconstruction of flooded areas.

Land purification projects, Homeless projects, Schooling projects, Food projects, Education projects, Health parks, Employment projects, Development and research agency for new techniques, Decentralization of governmental service organizations, New governmental structure for local villages and municipalities, where the population expresses its wishes and the newly elected government will carry out the plans.

Since existing plans that have been worked out in detail must be revised according to the circumstances that are only now becoming apparent, this can be done in consultation with

national and international planning agencies in order to shape the implementation of the plans as efficiently as possible and to avoid duplication of effort.

How the development of the Genocide Project will turn out in its entirety is not yet foreseeable, and will certainly affect the implementation and scope of the planned projects.

Projects in the field of Energy, Health, Nutrition, will be among the main themes, where my invention and those of teammates can be widely shared, for a broad rollout in the world.

Should better solutions become known, we would be happy to work together to adopt the best of the possibilities.

Robert, Theodorus, Gradus, Brekel call sign (Rob)

Dear co-investor fund holders.

Every one of you who is going to change will receive a large sum for his or her plans.

To avoid wasting double energy and money I have a proposal to become part of an investment collective.

Because the project plans often overlap, but also because spread across the Netherlands or Europe is a good thing, by working together.

Together we are stronger and can achieve.

If the rumours are true, a 1:1,1 exchange or even a 1:1,2 exchange could be possible without having real detailed plans.

Apart from that, there are plans that are going to be started.

There will be a foundation, which will shape the whole organization, including a plan and implementation office.

You will be able to participate in this, without being directly in sight.

I will also participate in this, and divide the money that I am going to get into 200 parts, of which I will invest 1 part per 3 months this foundation, which means a total period of 50 years.

All plans are going to be worked out very well and then started.

Everything that will be purchased will be in the name of the organizing foundation, which takes some of the worry away from the individual investor.

Because everything that is owned also has obligations to maintain it, and this can be done much better in a collective which can take a lot of care and responsibility away from the investors.

There will be a VIP arrangement for the affiliated investors, where proposals and solutions can be put forward by everyone.

Travel, hotel bookings and payments, but also active help at unexpected moments anywhere in the world belong to this service, and will be paid from the collective.

Also personnel and resources needed for projects are paid from the collective and give the investor the space to live or carry out his own life or projects anonymously.

Everyone is free to participate and work together as a collective.

If you choose for the collective, it must be fixed and linked to a period of time for participation in the collective.

We can make an appointment in cluster times of 5 years, in which case you enter into a 5-year agreement and make 20 quarterly deposits from your own budget that you have received.

Before the end of the 5 year period there will be consultation whether this working method will be continued for the investor, and will be extended again for a period of 5 years.

Be aware, despite all the good intentions, there will have to be quality, of which it is a learning process for everyone to realize the plans.

Consider this writing as a proposal, to join forces, of course there may be proposals if they contribute to a solid working method.

I prefer simplicity and transparency, so I don't want it to become a repository of suffocating or confusing rules.

If you decide to help shape the plans as a collective, by joining forces and experience, I would like to receive a commitment to this.

Everyone is free to participate, people who think they can do better on their own, I wish them good luck with their projects and aspirations, in all cases everyone will have control over their own funds.

That we get the funds will not be a coincidence, there is also a moral obligation to give poverty, the homeless, the elderly and youth a good future.

If you would get an amount of 1200 Billion per 100T, this is about 3 times the current state debts of the Netherlands, this to give you an impression of wealth that you are trusted to share with others.

Greed, power, or stinginess will ruin your life, where the wealth will be a curse for anyone who does not want to share it.

It is precisely the projects to do this in a coordinated way, and to reward people who are committed to help shape the transition.

The Transition, which starts with a lot of money, will ensure that in the long run money will no longer play a meaningful role when everyone is aware that working together makes money superfluous.

What is paying now, will soon be the granting of money among each other, that the new will be normal and self-evident in the future.

Precisely by using the period over 50 years, we have the time to grow towards this, where you have secured the future of your own family environment for this period through your own funds.

Apart from that, the foundation of the collective has an obligation to take care of the investors over the 50 year period.

Collaboration by different investors also means respecting mutual anonymity, whereby the collaboration is entrusted externally to the ReVive Invest Trust.

This prevents cock behaviour or the mutual imposition of ideas and an EGO competition, because that is the last thing we need.

Nobody has to unsubscribe if they don't want to participate, you can only sign up if the plan of action appeals to you.

A discussion about whether or not you want to participate is not desirable on my part, this is my proposal, you can say yes or no to that.

It is of no use to sink into each other's discussion for your own right, or difference of opinion.

I know from experience that we are stronger together, and that we can carry the responsibility better.

After all, you supervise and have a say in your own projects, but only on the basis of a spectator or anonymous employee when that need arises.

We have to have fun and not let ourselves be stressed by imposed restrictions.

It is also a trajectory of collective growth in knowledge and cooperation, and respecting each other for the commitment, in which the talents are bundled.

The people who are in favour of this set-up react, and are approached when the first stone of the organisation has been laid, in order to get started.

It is an ultimate opportunity to move from striving to DOING, and to shape the implementation, in which everyone can and will grow in their new role to make the transition a success as a collective.

If you have an amount of 1.2 Billion and don't use it, it doesn't have any value in this transition period, it's molding away.

Greetings Rob

13 dec 2018

Projects R.T.G. Brekel, cost estimation based on current money value. This does not take into account possible inflation, deflation or other factors that may influence the value. All plans can be considered humanitarian projects because they provide education, development, employment and income and food on the basis of ecological objectives.

Partly based on realistic estimates and expectations for the total project execution, these projects are carried out by self-managing teams.

I would like to have reserved the total amount of €46,130,681,822,400, and go and see what is really used to achieve the objectives. Starting with € 50.000.000 per month. In consultation with an asset manager we will adjust the amounts as the projects progress and there is more need for money.

Energy project development: Ultrasonic Hydrobooster €400.000 By
development for wider usability €1.600.000

CO2 free clean energy can be used for heat generation, cooling, water purification, water extraction from seawater, electricity generation, unlimited to connect after wish and energy needs.

Energy Project production Ultrasonic Hydrobooster for Europe including magnet generator assembly 200.000.000 pieces in 20 years **300.000 jobs** a € 59.000 = € 11.800.000.000.000 free supply to population, production spread over all countries in the world, Zimbabwe will have to be approached if they want to carry out a large part of the production.

ReVive Resorts, 90 ECO parks in Europe for preventive health, relaxation, learning project, healthy food education, adventure by Multi D Labyrinth and animation activities per park 1200 jobs on average = **108.000 jobs** cost covering exploitation, total park cost budgeted on average per park investment €135.000.000 x 90
= €12.150.000.000

Chlorine soil and soil remediation: acquisition patent / development costs €160,000 tool supplies + salary **2400 jobs** for 20 years
= €37,692,162,400

Research costs new clean techniques: €20,000,000 per year, over a period of 20 years **300 jobs**
= €4,000,000,000

Education various new and existing techniques and crafts for **3000 jobs** over a period of 20 years = €40,000,000,000

Materials and supplies for 20 years for **120,000 students** €50,000,000,000,000

Cultural history heritage renovation project 2550 pieces for Europe: Purchase and restoration costs €20,000,000 for 20 years **216,750 jobs**
= €61,837,500,000 After restoration operation covering costs.

Food project via Farmers, **5000 jobs** for GMO free healthy food for 500,000,000 Europeans calculated €2.5 per day, €456,250,000,000 per year x 20 = €9,125,000,000,000

Free Life World projects portal **1.500.000 jobs** 20 years
= €25.000.000.000.000

2,255,45 jobs 40 hours / week ----- 5,012,111 jobs 18 hours per week for 20 years,
investment costs for 20 years Total = **€46,130,681,822,400**

6 marche 2019 Vitansess project 90 pice for Europe letter to communiti Landgraaf

Dear Frank, Ramon, Ed, Marc, Ad, and Ingolf Kruseman, graphic designer.

Subject: Summary of the meeting with:

Alderman Ramon Lucassen, Ed Cleassen, Ad Sijen, and Frank Geurts from the Land Affairs Department of the Municipality of Landgraaf, regarding the Gravenrode project and the associated investments.

It was agreed that, based on the information already sent, a new document will be drafted in clear and understandable language to present the intent and structure of the plan to the municipal council.

This is expected to take approximately two months, after which I intend to submit the plan to the municipal council for review and approval to convert the plans into a concrete project.

To demonstrate that financing is underway and exactly how this will proceed, a bank guarantee covering the costs for the municipality is a decisive factor in discussing further possibilities together. Here is the historical link to the Swissindo Fund: <https://uitleg-gesara-nl.blogspot.com/>

The initiative concept will need to be further developed into a final concept that does justice to the entire plan, whereby the municipality of Landgraaf can help determine the details of the entire plan through public participation, while recognizing the need for free-form designs that deviate significantly from current architectural norms.

I have spoken with Ingolf Kruseman about collaborating with the ReVive Resorts World Team on the future implementation of the Landgraaf Plan.

ReVive Resorts BV will be established in Landgraaf, where I intend to purchase the property from the municipality at Voltastraat 11 in Landgraaf, provided the municipality approves the proposal and plans for the theme park—which will complement the castle gardens, architecture, various country themes and eras, preventive health initiatives, and a job creation project for over 1,200 jobs in Landgraaf.

It is a futuristic project with a nostalgic twist; here is an example: the Venus Project (<https://www.thevenusproject.com/the-venus-project/jacque-fresco/>), where health and nature are integrated into a living environment, with the difference that the ReVive project also incorporates cultural heritage and health in a futuristic form. Stemming from the 5,700 patents that will be made available to humanity as a supplement to plans from my own network, which I now have all over the world.

Ingolf Kruseman has previously created a presentation titled Vitanness and wishes to adapt this presentation to the new facts and names arising from the collaboration in order to further develop the plan together.

It is good to know that the Verbeek Landscape Planning Office in Maastricht may be able to contribute to this development, including the land price that Mondo Verde will pay for 22.5 hectares—€295,000 in 2026, which amounts to €0.76 per square meter.



Whether the municipality contributes the land for a symbolic amount of €1 to promote employment with a 50% profit-sharing arrangement to fund its own projects, or whether the municipality sells the land, this decision rests with the municipality. The land adjacent to the oak forest up to the highway between Brunssum and Kerkrade could also be included in this plan to create more jobs.

From the municipality's perspective, a sale based on a price per square meter seems more realistic, as we would then avoid a discussion about a profit model that lies five years in the future; for a total of 180 hectares, this amounts to €1,368,000 + €549,000 = €1,917,000

The entire plan also includes the integration of the current Mondo Verde, which I intend to acquire at the property tax value assigned to it by the municipality, excluding the land that is currently leased.

The Slot Schaesberg project will be the first to receive attention and be taken over, with the foundation being supported with assistance and resources.

The acquisition of the Slot Schaesberg Project by ReVive Resorts World serves as a guarantee for the funds to be invested; all staff will be transferred to Free Life World.

Through www.freelife.world, the municipality itself can apply for funds to finance future projects.

All individuals currently receiving welfare benefits will receive an income through Free Life World and will be able to participate in sub-projects and training programs for the overall plan, across various phases.

The building at Voltastraat 11 will serve multiple functions: it is a reintegration workshop for the ReVive Resort Park, a laundry facility for the park with storage space, office space during the construction of the ReVive Resort Park, and a practical learning and production center.

Once the prototypes of my energy products (<https://Ultrasone-Hydrobooster.blogspot.com> and related products) are ready and further developed, part of the production will be located in the region, which will also create many jobs; these and other new technologies will be implemented in the design of the entire park to create a self-sufficient park.

Given the scale and ambitions of the plans in Landgraaf, this requires a serious approach, provided it is clear whether the park can and may be built for Landgraaf and the Parkstad region.

It is too simplistic to say we will simply give a presentation in which we can only propose a concept that will serve as the basis for the detailed design.

Because the real work only begins once the municipality is willing to support this ReVive project in Landgraaf with its approval and cooperation.

The entire plan is also intended to support vocational training and apprenticeships for young people; those who are developing into creative individuals can fully express themselves through this project.

We have discussed the firing of field bricks, and these young people, in collaboration with volunteers from Slot Schaesberg, can offer this as a complementary service.

We then discussed involving Mondo Verde in the plan and offering them a purchase price based on the property tax value, whereby the current owner would be allowed to retain the profits from operating the park under ReVive's supervision for up to six months prior to the opening of ReVive Resorts World, during their operating period until the merger with ReVive.

If the municipal council has any further questions or comments, I would appreciate hearing them. Should Mondo Verde not wish to be acquired, they will never be able to compete with ReVive's plans and operations.

The potential acquisition of Mondo Verde is a key factor in the overall design of the plan, as a parking garage on the current Mondo Verde property is included in the plans.

Detailed Project Description: Gravenrode Health Eco-Resort Park

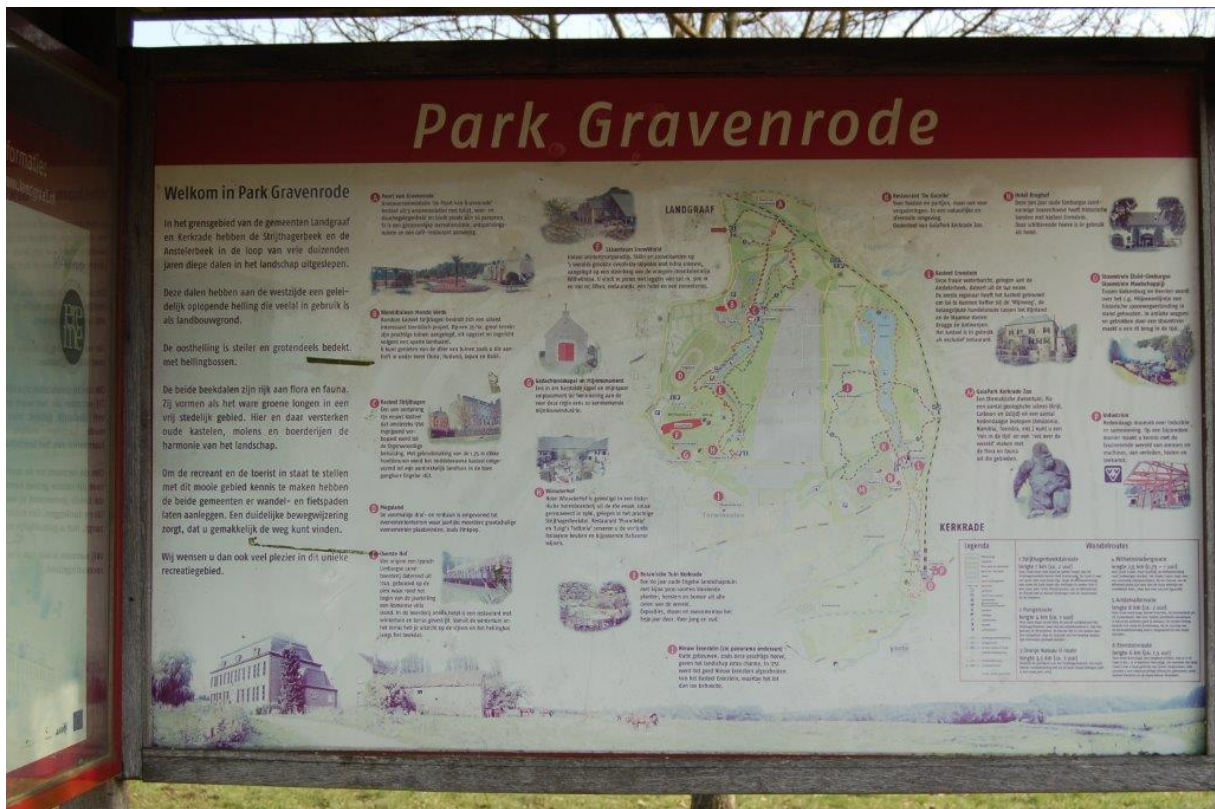

To the Municipal Executive, City Council, and Mayor and Aldermen of the Municipality of Landgraaf.

Due to increasing automation, many jobs are disappearing, and this must be offset by a fair and equitable distribution of work to give people a sense of purpose and self-worth.

We will therefore have to let go of the old paradigm, which is based on work and income, especially as even more jobs will be lost to automation in the future.

The goal of these plans is to connect talent within a social society, where people stand up for one another and care for one another as they once did.

A good example is the restoration of Slot Schaesberg, where people with intellectual disabilities are contributing to the restoration. That is why we also want to support this project and consult with the Slot Schaesberg Foundation on how we can shape this initiative.

The idea is to use some of the excavated soil from the ReVive eco-resort project in Gravenrode as clay—the base material for firing field-fired bricks and roof tiles.

This, too, will become an active learning and development process focused on connecting people

through a shared objective.

The aim is to award the necessary craftsmanship and contracts to local businesses as much as possible.

This will give small businesses a renewed sense of purpose and allow them to once again become the driving force of the local economy.

The proposed project in Landgraaf is expected to create over 1,200 jobs, though this will depend in part on how much land area is made available for the project.

Training and education for staff have been incorporated into this plan to foster insights and skills.

Medisch personeel bezetting per park	131
Park dienstverlening en onderhoud.	
Parkbeheerders hoveniers	240
Wasserij	30
Hotel / Restaurant personeel	300
Technisch onderhoud	90
Administratie	60
Animatie team	40
Workshop Team	16
Wellness personeel	120
Schoonmaak dienst	120
Parkrangers/ EHBO/ veiligheid preventie	60
Oude ambachten personeel	12
Financiële park management	2
Jobs total	1.221

The ReVive Resort Landgraaf will therefore not only serve as a journey of self-discovery but also as a model for the rest of the world.

Given the plan's extensive scope, we must take into account that developing this park could take well over a year.

The Municipality of Landgraaf will become a topic of conversation for the rest of the world when people realize that this project is not only an educational initiative but will also serve as a knowledge center where the latest technologies will be integrated.

This is separate from the goal of creating a design that is as unique as possible, with support from the local population and the Municipality of Landgraaf.

Money is not the goal but merely a means to collectively pursue the objective.

That is why a call is being made to (fishing) and other associations, clubs, and theater groups in the Landgraaf area to offer, on behalf of their organization, to contribute in the form of volunteer work, should these plans in Landgraaf proceed.

In doing so, the associations can count on financial support for the

volunteer work provided, provided there is agreement on the plans from within the association.



This will foster a sense of community, and we hope that the public will embrace this plan and appreciate its true value.

To maintain a clear separation of interests, the Municipality cannot participate in a business, even if it takes the form of an eco-resort.

To ensure the plan proceeds smoothly and to prevent stagnation, the zoning plan, in accordance with existing laws and regulations, supports reintegration or a learning pathway as much as possible, with the support of the administrator and the Municipality of Landgraaf.

All of this is aimed at developing new initiatives wherever possible. The investor's goal is not to own but to share. Sharing multiplies happiness, knowledge, prosperity, and well-being.

However, to ensure that an investment of this magnitude proceeds smoothly, all necessary legal requirements must be properly addressed. Companies will therefore be established that comply with national regulations and administrative requirements.

This project description is not set in stone but will be discussed on an equal footing with the investor's direct representatives, the future park managers, architects, and project developer.

People with specific skills, insights, and experience from other working groups will be invited to jointly further shape the ReVive Resort Park Gravenrode.

The artist and current resident of Strijthagen Castle, part of the Gravenrode estate, has been offered the opportunity to make an exhibition of his artwork freely accessible to the public in exchange for a fee, naturally during hours of his own choosing.

In this way, the entire 5 hectares of his private property will become accessible to the public.

Other residents and/or operators can be included in the overall concept, allowing them to continue their own activities.

A few highlights from the plans: an open-air theater with a retractable roof for approximately 500 people

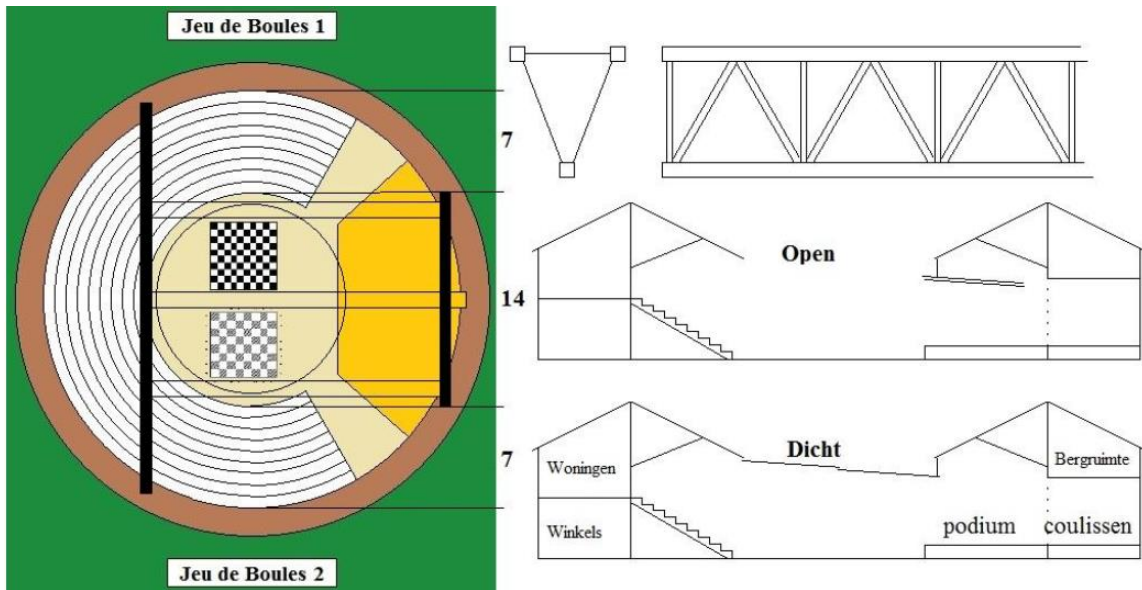

Een Vulkaanhotel met meer als 350 bedden.

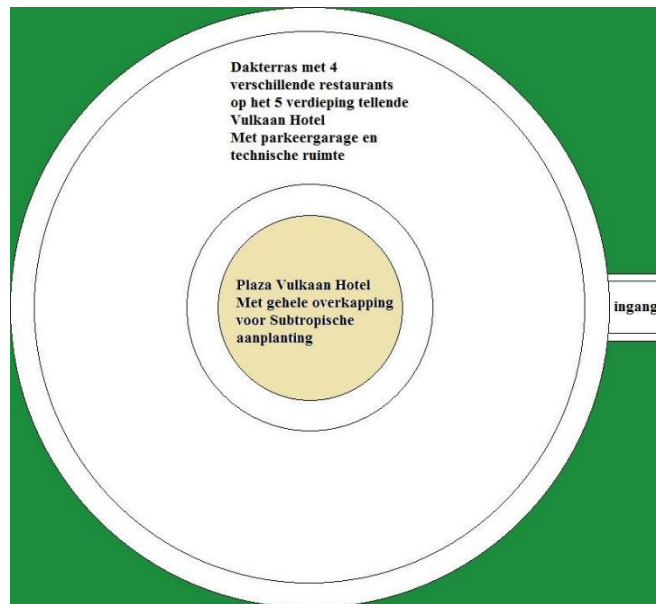

Spa hotel with 138 beds.



ReVive Resorts BG Office Building

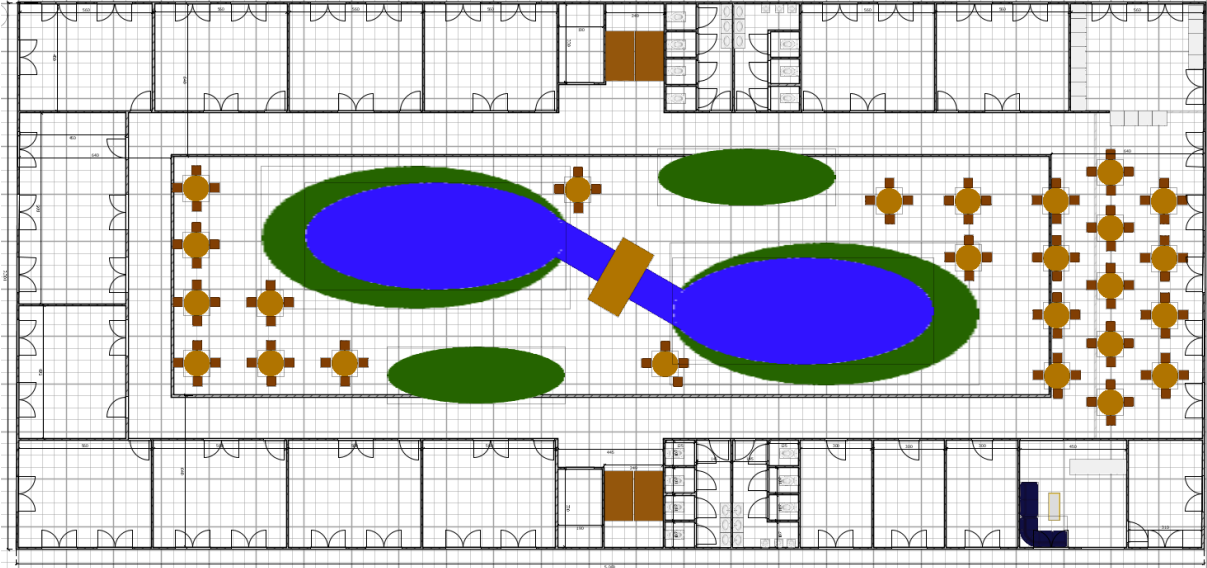

ReVive Resorts Office Building, 1st Floor





3D Labyrint

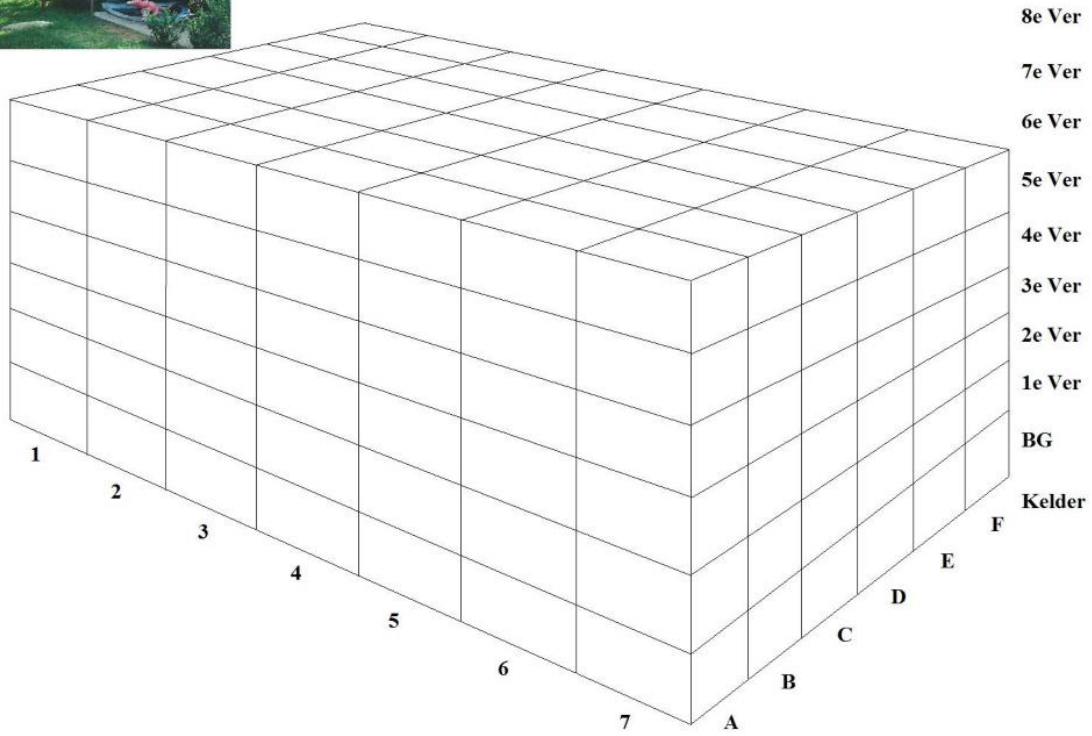

Ground floor layout of the Multi D Labyrinth.



Taverna Antiqua
Tomar

Terms and conditions will be an evolving process that we must handle with care as we shape the project in Landgraaf together.

The financing of the entire plan depends on the global geopolitical and financial developments currently underway; by this I mean the timing of when funds will become available and the conditions attached to them.

Based on the information in this link, we can expect these funds to become available starting March 20, 2019.

A. March 5 2019 The Big Call,

Bruce: https://www.freeconferencecallhd.com/wall/recorded_audio?audioRecordingUrl=https%3A%2F%2Frs2941.freeconferencecall.com%2Fstorage%2FsggetHD%2FHsCgW%2FaGy6&subscriptionId=949547 712-770-4016 pin123456#

1. The true RV began on Friday, March 1. RV = a revaluation of all currencies worldwide across all 209 member countries, in which money is once again backed by gold.

Global money creation was in the hands of the FED in the U.S., owned by private bankers; their license was valid from Dec. 23, 1913, to Dec. 22, 2012, with a grace period to ensure that the monetary system would be replaced by gold-backed assets.

You now see populations worldwide rising up against the ruling class; people are desperately donning yellow vests to express their discontent.

To make the transition possible, many things will have to change; a protocol has been written for this called NESARA, which the rest of the world will call GESARA, the National or Global Economic Security and Reform Act.

This means that all the wealth on Earth has been re-inventoried, and the currency values of 209 countries will undergo a revaluation.

The funds available through Swissindo alone amount to €127 million per person, backed by the gold reserves of Indonesia and the Philippines.

This is only a small portion of the wealth that will be released; another major source of backing for the new monetary system is Zimbabwe, whose mineral resources—including 16 billion kilograms of gold, diamonds, oil, and other rare commodities—provide the backing for a new fixed-value monetary system.

You can see that this is a geopolitical and financial matter that affects us all.

2. The Iraqi ATMs were loaded with the lower denominations.

3. The Gazette release in the morning March 6 would have the new Dinar rate.

4. The new rate on the Iraqi Dinar would start at \$6-\$7 and trade upward.

5. Everything would flow starting at midnight tonight – the 8-9 different funds would start paying out.

6. Things would be signed off by morning.

7. The 800s would be out some time between tonight **March 5** and before noon on **Thurs. March 7**. We should be at our exchanges within 48 hours.

8. Banks in the US would be Basil 4 compliant before the end of the month.

9. We should have 8-10 days to redeem Zim before the general public could exchange.

There will certainly be skepticism about the funds that are ready to be spent, which is why I ask that we think in terms of possibilities rather than limitations, because as far as we're concerned, we'll make it work ourselves.

These funds are being made available precisely to combat a recession.

If people have nothing to spend, they cannot participate in the current system and are excluded due to a lack of funds, which further undermines the economy.

The cost estimate for the ReVive Resort Park is based on a similar design from the past by Ingolf Kruseman, for a park that was much smaller than the current plan.

The estimated €270 million for the project will also include the purchase of Mondo Verde; a potential tunnel over Mensheggerweg and Dr. Calsstraat could push the price slightly higher.

We will develop the entire project together and assess, phase by phase, what actions we need to take to implement the overall plan.

The cost of €270 million is secondary to the implementation of the plans; we do not intend to cut corners to stay within this budget and thereby compromise on quality.

The entire plan is specifically designed to provide strong economic support to the region and create jobs, while mitigating potential risks for local businesses. This will be addressed later once the municipal government provides the necessary support for the plan—I am not asking for money from the municipality, but rather for cooperation.

This will partly determine whether I will proceed with the purchase of the property at Voltastraat 11, as everything is interconnected.

That is why I am requesting that this information be shared with the entire municipal council to see if my proposal could be a viable project for Landgraaf.

A visually appealing presentation will be provided at a later stage if deemed appropriate, using the previous Vitans presentation as a basis.

We can work out the finer details together later; focusing solely on limitations without considering the possibilities will not yield any results.

The time I have invested in all of this will not be wasted, as other countries support these plans; it has proven to be a valuable learning process.

Warm regards,

Rob Brekel